



90 and 120kVA Diesel Engine Driven GPU Cummins B5.9 Diesel



HOBART: “A NAME YOU CAN TRUST”

Hobart offers the best combination of superior design, performance, proven reliability, and value to meet the critical needs of the airline industry with our series of modern ground power units. Integrating the *best in technology, customer influenced design* and Hobart’s years of *engineering expertise*, our Ground Power Units can be trusted to meet your aircraft’s needs for quality 400Hz power.

DESIGNED FOR DURABILITY:

Low profile, combined with standard 5th wheel (turntable) steering, provides superior visibility and maneuverability in congested ramp areas, while the durable bumper system protects the unit from damage caused by other GSE.

POWER FOR PEAK PERFORMANCE:

The Hobart Cummins diesel powered GPU’s feature the “B” series 5.9 liter diesel engine, combined with a Hobart designed and manufactured generator, to maximize GPU performance while maintaining the traditional Hobart reputation of longevity and durability.

CE and EMISSION CERTIFIED:

Hobart teamed with Cummins to specify the most technically advanced engine designed to meet both current and future Emission Standards. CE Certification and international labeling is an added feature of this GPU.

PERFORMANCE FEATURES

- Fully Emission Certified Engine
- Noise “Isonorized” design with optional noise reduction kit
- Large stainless steel fuel tank and low fuel warning are **standard**
- Delayed stop (for turbo protection) and emergency shutdown are **standard**
- Hobart-designed and manufactured generator offers long life and reliability
- Racor® fuel/water separator is **standard**
- Numbered, color-coded wiring remains traceable for the life of the unit
- 5th wheel (turntable) steering features maintenance-free nylon bushings
- Choice of drum type braking systems: tow bar activated or hand brake activated
- Superior regulation via electronic controlled engine governor system
- Lift-off doors and pop-out panels provide easy access to engine, generator and control compartments

Model	KV	KW	Outputs	Engine Model	HP	Unit Weight
90CU24	90	72	1 or 2	6BT5.9C	165	5600 lbs. (2540 kg)
120CU24	120	96	2	6BTA5.9C	200	5600 lbs. (2540 kg)

Hobart is an ISO9001 Certified Manufacturer

Hobart Cummins Engine Driven Ground Power Unit

Specifications

Engine

- Cummins B5.9 diesel operating at 2400 RPM
- Turbocharged 4-stroke, inline 6 cylinder and fuel pump
- Full application approval by Cummins Engine Co., Inc.
- 12VDC battery system
- Low oil pressure shutdown
- High coolant temperature shutdown
- Intake air restriction indication
- Stop lever governing for precise control and longer life
- Electronic governor system
- Automatic cold weather ether start

Environmental

- Operation temperature:
 - 25° F to +125° F
 - 31° C to +52° C
- Relative humidity 0-100% noncondensing
- No altitude derating required up to 10,000 feet, when running in normal operating range

Performance

- Rating: 90 or 120 kVA, 3 phase, 4 wire, 115/200 volt Wye, continuous
- Meets or exceeds MIL-STD-704E Electrical Power Quality Requirements

Overload

- 125% rated load for 5 minutes, 150% for 10 seconds
- Individual outputs: 324 amps, 5 minutes

Voltage

- Transient voltage recovery time: to within $\pm 1\%$ in 100 milliseconds (no load to rated load)
- Within $\pm 20\%$ deviation upon application/removal of 100% load rating
- Modulation: does not exceed 0.5% of steady state voltage
- Phase voltage displacement with balanced load: 120 ± 1.5
- Phase voltage balance (with unbalanced load) does not exceed 4% with 1/3 rated current on any single phase with other two phases disconnected

- Crest factor: 1.404 ± 0.07
- Individual Harmonic Distortion: $< 2\%$ of the fundamental (RMS) voltage
- Total Harmonic Distortion: $< 3\%$ of the fundamental (RMS) voltage

Regulation

- Voltage Regulation: $\pm 1\%$ no load to full load
- Voltage adjust: ± 15 volts
- IHD (individual harmonic content): $< 2\%$
- Three phase average sensing, built-in line drop compensation, up to 5%
- Line Drop Compensation: Automatic up to 5%

Frequency

- Regulation: ± 2 Hz steady state
- Transient recovery: to within ± 5 Hz in < 2 seconds per ARP 5015
- Modulation: $< 0.25\%$ (1Hz)

Protection

- Meets MIL-STD-704E
- Overvoltage: instantaneous disconnect of load at 180 volts L-N, with inverse time delay down to 126 volts in 2 seconds
- Undervoltage: disconnects output below 100 volts L-N in 7 seconds
- Overfrequency: disconnects output above 420Hz in 5 seconds
- Underfrequency: disconnects output below 370Hz in 7 seconds

Finish

- Anti-corrosive Polyester powder provides excellent weather resistance, flexibility and adhesion, plus a strong resistance to chemical agents such as glycol and skydrol
- Standard colors are high gloss white over black frame and chassis
- Custom colors require a paint chip or swatch for accurate color match

Displays / Instrumentation

Engine Operation

- **Meters:** coolant temperature, ammeter, hour meter, oil pressure, fuel level
- **Indicator lights:** engine circuit on, air cleaner restriction, high coolant temperature, low oil pressure, engine stop delay action, low fuel
- **Switches:** Engine start, engine stop, panel lights
- Delayed shutdown for turbocharger protection

Generator Output

- **Meters:** frequency, ammeter, voltmeter
- **Indicator Lights:** contactors on, overfrequency, underfrequency, overload, overvoltage, undervoltage
- **Switches:** meter select, output contactors control, test/reset

Trailer

- Tire size: 20.5 x 8.00 - 10
- Ground clearance: 9" (.23m)
- Brakes: Tow bar activated, drum type

Available Options:

- Noise reduction kit
- Block heater kit (120V/60Hz or 240V/50Hz)
- Transformer-Rectifier pack for 28.5VDC
- Automatic towbar height stop
- Pintle or pin hitch
- Spot light
- Alternative mounting configuration: stationary/ fixed or truck mounted
- Special paint scheme
- Hand activated brakes
- Battery blanket (120V)
- Indicator beacons (low fuel, operating)
- Low fuel warning / shutdown
- Second output (90kVA model)

Specifications subject to change without notice.

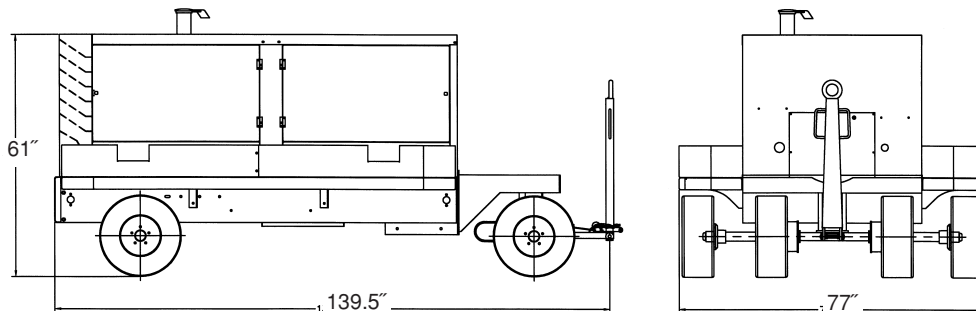

ITW **GS GROUP**



Hobart Ground Power • Headquarters & Factory: 1177 Trade Road East, Troy, OH 45373 U.S.A.
Phone: 1-800-422-7253 or 937-332-5080 • Fax: 937-332-5799
E-mail: hgpsales@itwgsigroup.com • www.hobartgroundpower.com

Hobart Beijing Office • Phone: 86 (0) 10 8739 7900 • Fax: 86 (0) 10 8739 7600

Hobart International (UK) • Phone: 44-1723-370437 • Fax: 44-1723-370125