

5050 Heater

TRILECTRON'S AIR-A-PLANE DIVISION
400,000 BTU/HR, Diesel engine driven heater



Model 5050 Trailer Mounted

TRILECTRON/AIR-A-PLANE:

Trilectron Industries and air-a-plane products division have led the industry in product design and innovation. The best combination of experience, new technology and customer input has resulted in a product line you can trust for your aircraft's needs.

APPLICATION:

- Completely self-contained mobile trailer-mounted heater for comfort conditioning of passenger aircraft.
- Powered by a Deutz Diesel engine with approximately 12.5 hours of operation.

CE AND EMISSIONS CERTIFIED:

All engines meet current Tier Emissions Certifications as specified by EPA and CARB. CE Certification and international labeling is an added feature of this equipment.

PERFORMANCE FEATURES:

Three sources of heat:

- Blower heat of compression, engine coolant heat and engine manifold heat. No open flame.

Easy to Operate:

- Designed to operate for extended periods of time unattended in an airport environment.
- Low Fuel Indicator Light and Glow Plug Start Assist Ready Light.

Economical:

- Blower fan mounted directly to the engine flywheel requiring no clutches, gears or pulleys.
- Fewer moving parts equate to lower maintenance costs.
- High efficiency output through the use of reclaimed engine heat.
- Fuel efficient: significantly less cost than running the aircraft APU.

Durable:

- Designed to endure the rigors of the airport environment with heavy-duty running gear, 5th wheel steering and a weatherproof canopy

Model	Heating Capacity	Engine	Length	Width	Height	Weight
5050	400 MBh (117 kW)	Deutz 1011	96" (244 cm)	60" (152 cm)	67" (170 cm)	3,900 lb (1,773 kg)

Trilectron's Air-A-Plane Division 5050 Heater Specifications

Engine

- Deutz 1011, variable RPM
- Turbocharged 4-stroke, inline 4 cylinder
- Diesel and Jet Fuel Compatible

Environmental

- Operation temperature: -40°F (-40°C) to +65°F (+18°C)
- Relative Humidity 0=100% noncondensing

Performance

- Maximum Heating Capacity 400,000 Btu/hr (117.2 kW)
- Maximum Airflow 250 lb/min (113.6 kg/min)
- Maximum Static Pressure 28"wg (6.98 kPa)

Protection

- High Oil Temperature
- Low Oil Pressure
- Low Oil Level
- High Discharge Air Temperature
- Low Fuel Level
- Low Battery

Finish

- Anti-corrosive polyester powder provides excellent weather resistance, flexibility and adhesion, plus a strong resistance to chemical agents such as glycol and skydrol
- Standard colors are high gloss white over black frame and chassis
- Customer colors require paint chip or paint color code and paint manufacturer

Displays/Instrumentation

- Meters: Engine Oil Pressure, Engine Oil Temperature, Engine RPM, Volt Meter, Engine Hour Meter, Discharge Air Temperature
- Indicator Lights: Low Fuel, Low Oil Pressure, Low Battery Voltage, Glow Plug Activation
- Switches: Stop, Start, Throttle (Throttle on Manual Control Only)

Trailer

- Tire size: 6.90 x 9
- Ground Clearance: 8.75" (22.2 cm)
- Brakes: Towbar Activated

Available Options

- Automatic Temperature Control With Discharge Air Thermostat
- Battery Disconnect
- Sound Attenuation: 85 dba avg @ 5m (16.4')
- "Soft Shoe" non-pneumatic tires
- Low Fuel Warning
- Oil Heater, 120V or 240V
- Extended Hose, Insulated (30' x 12" D)

Specifications subject to change without notice.

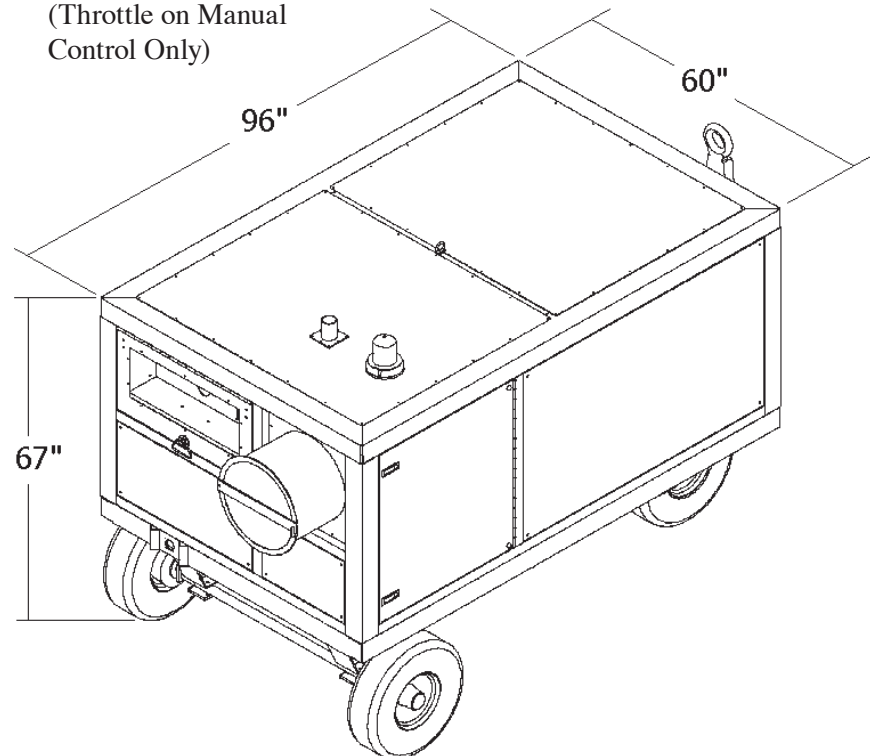

Trilectron Industries

Headquarters & Factory: 11001 US Hwy. 41 North, Palmetto, FL 34221 U.S.A.
Phone: 941.721.1000 • Fax: 941.722.5327
E-mail: tisales@itwgsegroup.com • www.trilectron.com

Trilectron Asia Office

Phone: +852 638 07 883 • Fax: +852 264 14 489

Trilectron International (UK)

Phone: +44 1723 370437 • Fax: +44 1723 370125

Updated 02/20/09

An Illinois Tool Works Company